

**Chair:**

Tony Peleska

**Secretary:**

Gary Gerding

**Board Members:**

Aisha Elmquist

Linda Hansohn

Kathy Johnson

Susan Johnson

Renee Marino

**Staff Liaison:**

David Swearingen



**Karth Lake Improvement  
District Board  
REGULAR MEETING**

**Tuesday  
April 13, 2021**

1245 W. Highway 96  
Arden Hills, MN 55112  
651.792.7800  
[www.cityofardenhills.org](http://www.cityofardenhills.org)

**Agenda  
Board Meeting Convenes at 6:30 PM**

**CALL TO ORDER****1. APPROVAL OF THE AGENDA****2. APPROVAL OF MINUTES****3. BOARD MEMBER ELECTIONS**

A. 3-year terms (expire April 2024) (2)

B. 2-year terms (expire April 2023) (2)

C. 1 year term (expire April 2022) (1)

**4. ELECTION OF CHAIR AND SECRETARY****5. PUBLIC INQUIRIES:** None**6. OLD BUSINESS****6.1 Remediation of BMP #1 Site**

**6.1.1 Background:** Q: Board members expressed concern about the likelihood that future construction in Shoreview that is within and near the Karth Lake watershed could add more runoff and nutrients. This could increase the water level and pollution of Karth Lake. Board Members thought the lake levels have varied higher since the townhouses were built east of Lexington Ave. Board Members have observed significant water flow into Karth Lake from the holding pond east of Lexington and Karth Lake.

**6.1.2 Report from Kyle Axtell:** What controls are in place to prevent an increase in Karth Lake water level and nutrient load caused by new construction in Shoreview?

**6.2 Progress Report on Protection of Pump and Control Panel**

**6.2.1 Background:** At our January meeting Linda reported that she has seen people climbing on the pump station in the lake. Todd reported that the City found the entire pump station turned upside down. The Board recommended if anyone sees someone disturbing the pump, they should call the Ramsey County Sheriff at 651-767-0640 and observed that the Sheriff's job would be easier if there was a "No Trespassing" sign on the pump. The Board recommended that the City put a "No Trespassing" sign on the pump station. At our February meeting David said that Jeff Frid, Public Works Superintendent, will bolt a sign on the pump structure that says, "Warning, Stay Back." Board members again emphasized that the Sheriff's job of responding to calls would be easier if there was also a "No Trespassing" sign. Then it would be clear that disturbing it was not allowed by the city. Action: David will look into adding that sign.

**6.2.2 Update of action plan - David Swearingen**

**6.3 Progress report on additions and changes to Karth Lake portion of City website - Renee Marino**

**6.4 Maintenance and improvement of Art Larsen Memorial Gardens**

**6.4.1 Background:** Susan has worked with the City and several volunteers to remove weeds from the garden and add over 100 new plants. Watering has required hauling buckets of water the homes of neighbors nearby who volunteered to help. David said Jeff Frid would investigate the sprinkler system in the spring and modify it as needed to water the plantings.

**6.4.2 Sprinkler Status and Plans – David Swearingen**

**6.5 Add Grit Chambers to storm drains that empty into Karth Lake and do not have Grit Chambers now.**

Next Steps: Plan to identify them; Identify likely dates for adding Grit Chambers.

**6.5.1 Background:** David will work towards identifying storm drains that empty into Karth Lake but do not have a grit chamber.

**6.5.2 Grit Chamber Status Update - David Swearingen**

**6.6 Lake Level Gauge**

**6.6.1 Background:** At our last meeting the Board asked David to research answers to the following questions:  
A. Does the gauge measure actual depth or is it just a reference point? B. How is it anchored?

**6.6.2 Gauge update – David Swearingen**

**7. NEW BUSINESS**

**7.1 History of lake level and depth data – Renee Marino**

**8. NEXT MEETING**

**9. ADJOURN**

**Draft Minutes for Karth Lake Improvement District Board**  
**Regular Meeting 6:30 PM, Tuesday, February 9, 2021**  
**Revised: 3/8/21**

**1. Call to Order/Roll Call**

1.1 The Zoom meeting convened at: 6:30 PM

**1.2 Present:**

**Board Members:** Gary Gerding, Secretary; Aisha Elmquist; Linda Hansohn, Chaired this meeting; Kathy Johnson; Renee Marino.

**Staff Liaisons:** David Swearingen, Interim Public Works Director.

**Karth Lake Residents:** Jason Rahn.

**1.3 Absent:**

Susan Johnson, Tony Peleska, Chair

**2. Approval of Agenda**

The agenda was approved as written with the addition of “Questions about Lake Level Gauge” added to new business.

**3. Approval of the minutes of the previous meeting:** The minutes of the previous meeting on January 12, 2021 were approved as written.

**4. Public Inquiries: None**

**4. Old Business**

**4.1. Progress Report on Protection of Pump and Control Panel**

**4.1.1. Background:** Linda reported that she has seen people climbing on the pump station in the lake. Todd reported that the City found the entire pump station turned upside down. The Board recommended if anyone sees someone disturbing the pump, they should call the Ramsey County Sheriff at 651-767-0640 and observed that the Sheriff’s job would be easier if there was a “No Trespassing” sign on the pump. The Board recommended that the City put a “No Trespassing” sign on the pump station. **Action: Todd agreed to investigate that option.**

**4.1.2. Report on “No Trespassing” sign – David Swearingen:** David said that Jeff Frid, Public Works Superintendent, will bolt a sign on the pump structure that says, “Warning, Stay Back.” Board members again emphasized that the Sheriff’s job of responding to calls would be easier if there was also a “No Trespassing” sign. Then it would be clear that disturbing it was not allowed by the city. David will look into adding that sign.

**4.2. Communication plan for KLID website: Staff and Board**

**Background:** The City has set up a KLID website that is ready to be populated and has assigned Gretchen Needham, the City’s New Communications Coordinator as the point of contact for additions and changes. Content should be Community focused. The Board agreed that the KLIDB Secretary should be the Board’s primary point of contact with Gretchen, and that all additions and changes in the KLID website should be approved by the Board. **Action: Gary asked the Board members to give him their recommendations for what should be on the KLID website. Gary will consolidate these, and we will make some decisions at the next meeting.**

**4.2.1. Recommended KLID website elements – Gary Gerding**

1. Main Duties – add to existing content: a link to the KLID founding documents and bylaws
2. Meetings
3. Agenda and minutes: add all available agendas and approved minutes
4. Membership: update with new election results
5. Articles about Karth Lake from Arden Hills Bulletin
6. Lake water quality testing and results.
  - A. Report of most recent results
  - B. How the measurements are done. CAMP: Citizen Assisted Monitoring Program Summary  
CAMP Manual

Link to CAMP Video training

7. Karth Lake Portions of Southwest Urban Lakes Study
8. Nursery Hill Lane Raingarden Design and plantings
9. Adopt-a-Drain Program

**4.2.2. Approved Additions to website – Board:** The Board agreed to the above list by unanimous vote. Renee offered to help with the additions, design and editing of content on the Karth Lake website. Gary gladly accepted the offer. Gary has extensive files of information to be added to the website. As that information is approved by the board for addition to the website, Gary will send that information to Renee.

The Board agreed: To appoint Renee Marino to be the key contact with Gretchen for additions and edits of the information to be listed on the Karth Lake website; to empower Renee to make corrections in material on the K. L. website as needed for accuracy.

## 5. New Business

### 5.1. Plan process for next election of KLID Board Members and Officers whose terms have expired.

**5.1.1. Plan process for announcement of election and invitation of candidates including media and message.** Background: The Board agreed the City should mail out an announcement of the election.

**Action: Kathy volunteered to draft the letter.** Gary made some additions and changes. The Board unanimously approved the following letter:

---

Karth Lake Neighbors,

This April, there will be an election of members of the Karth Lake Improvement District Board (KLIDB) whose terms are expiring. The KLIDB is comprised of elected Karth Lake residents who meet four times a year to determine and implement improvements to our beautiful joint backyard, Karth Lake.

Terms will run until: 2024 (3 members); 2023 (2 members) and 2022 (one member). Elections are every April. The process is simple. Email David Swearingen at [DSwearingen@cityofardenhills.org](mailto:DSwearingen@cityofardenhills.org) and tell him your street address if you would like to come to the April (Zoom) meeting and/or stand for election. At the meeting, candidates will briefly present their qualifications, and everyone present at that meeting will vote. There will also be an election of the Chair and Secretary for the next year.

How does KLIDB help? Glad you asked!

The board has worked with the City of Arden Hills, the DNR and the Rice Creek Watershed District on many projects. These projects have brought the lake from borderline eutrophic (green and unpleasant) to healthy. Our lake is truly a study in how thoughtful management can make a marked improvement.

Some examples of what the KLIDB has helped implement are:

water quality monitoring program and tracking

installing catch basins and rain gardens

fish stocking and weed removal

buckthorn removal and shoreline erosion management

water level management and pump maintenance

Please consider joining the volunteers of KLIDB. Meetings are posted on the Arden Hills city website and everyone is welcome to attend any meeting.

Thanks!

The Karth Lake Improvement District Board

---

## **5.2. Maintenance and improvement of Art Larsen Memorial Gardens –**

Background: Susan has worked with the City and several volunteers to remove weeds from the garden and add over 100 new plants. Watering has required hauling buckets of water the homes of neighbors nearby who volunteered to help. **Action: The Board asked Todd to report whether the City sprinklers in Cummings Park reach the garden and whether we could coordinate sprinkling with new plantings/dry spells, etc.**

**5.2.1. Sprinkler Status and Plans - David Swearingen:** David said Jeff Frid would investigate the sprinkler system in the spring and modify it as needed to water the plantings.

## **5.3. Long Term Strategic Plan Elements: Projects and Funding – Board & Staff**

### **5.3.1. Remediation of BMP #1 Site**

**Background:** Todd gave us an update of the status and plans at the last meeting, but we did not have time for questions. Questions for Todd include:

1. Q: On the figure below, do all the yellow lines indicate pipes? Please explain what each node and line represent. A: David: Yes, all the yellow lines are pipes or another water conduit such as a culvert.
2. Q: Show where BMP #1 starts and ends on this photo. A: David: The BMP #1 remediation is not on this map. See schematic below.
3. Q: Are the 2 nodes east of the northmost building a low spot where filtration takes place? A: David: Yes.
4. Q: Please explain the elements of the schematic of the Grading and Utility Plan. Q: David explained it.
5. Q: Does the remediation include any mechanism to catch solids -- like a grit chamber — so they do not get in the lake? A: David: The plan as drawn does not have a grit chamber, but a grit chamber will be included. **Action:** David will send us an updated schematic with the grit chamber shown. [That schematic was received after the meeting and is attached at the end of these minutes.]
6. Q: Is there any mechanism to capture oil products and other pollution and nutrients that are contained in the runoff from the parking lot and road before they enter the lake? A: David: No filtration is provided. This remediation step only captures grit and moves the water down the hill without causing more erosion. **Action:** David plans to apply for another grant in the future that will divert the water into a holding pond so it is filtered before it empties into the lake.
7. Q: Board members expressed concern about the likelihood that future construction in Shoreview that is within and near the Karth Lake watershed could add more runoff and nutrients. This could increase the water level and pollution of Karth Lake. Board Members thought the lake levels have varied higher since the townhouses were built east of Lexington Ave. Board Members have observed significant water flow into Karth Lake from the holding pond east of Lexington and Karth Lake. **Action:** We agreed to ask Kyle Axtell to tell us what controls are in place to prevent an increase in Karth Lake water level and nutrient load caused by new construction in Shoreview.

**5.3.2. Maintenance of existing pumping system: Do we recommend funding in advance with assessments? How much per year? When do we start? After Assessments for recent repairs end?**  
This item was tabled until a future meeting.

**5.3.3. Add Grit Chambers to storm drains that empty into Karth Lake and do not have Grit Chambers now. Next Steps: Plan to identify them; Identify likely dates for adding Grit Chambers. Todd Blomstrom and Board. Action:** David will work towards identifying storm drains that empty into Karth Lake but do not have a grit chamber.

**5.3.4. Lake Level Gauge Questions for David**

- 1. Does the gauge measure actual depth or is it just a reference point?**
- 2. How is it anchored? Action:** David will research the above.
3. Renee suggested it would be helpful to measure the lake levels in conjunction with biweekly CAMP samplings. The board agreed.

**6. Next Meeting:** Tuesday, April 13, 2021

**7. Adjourn**

Respectfully submitted,  
Gary Gerding  
Secretary

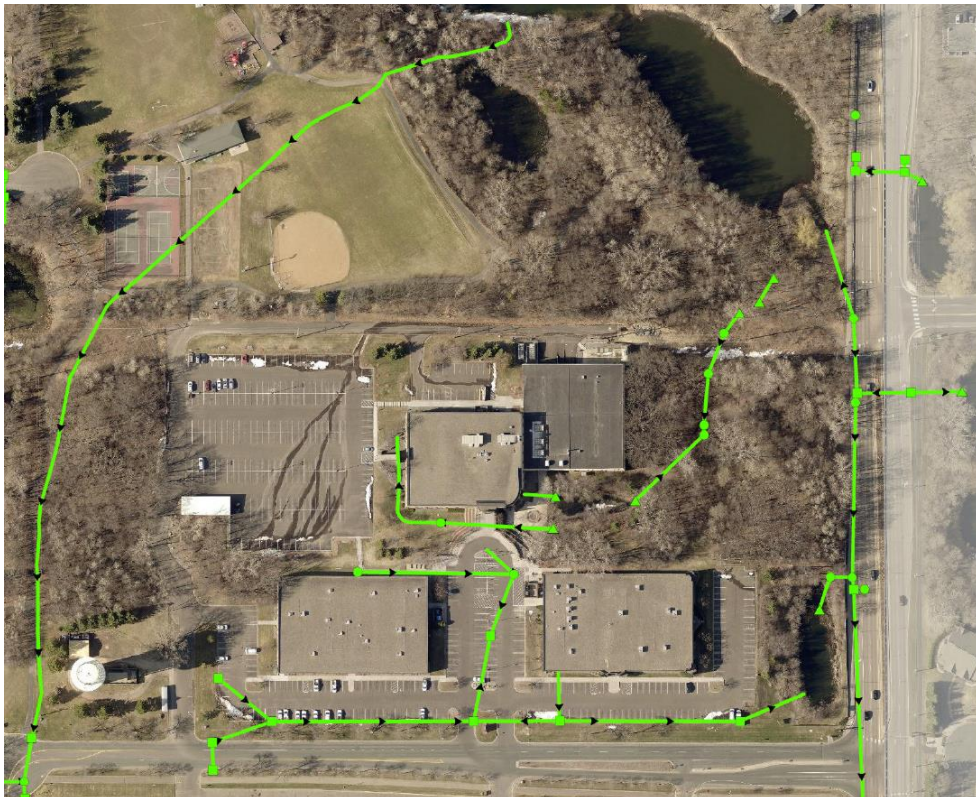

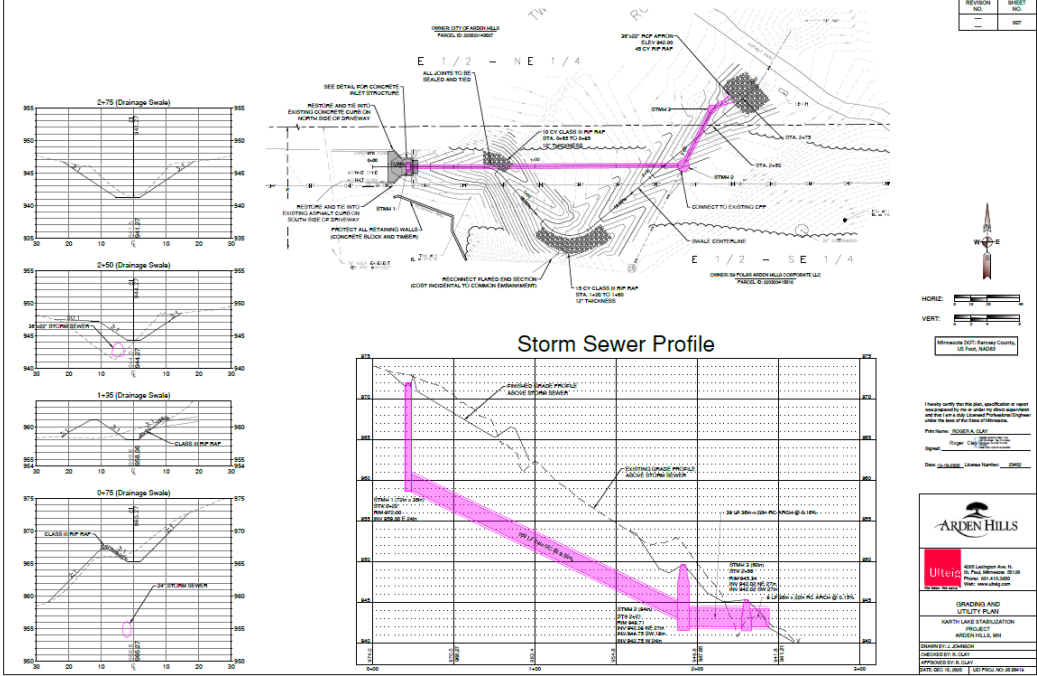

REVISION NO.	SHEET NO.
---	---
---	---



HORIZ.

VERT.

Minnesota DOT, Bureau County, US Post, NAD83

I hereby certify that this plan, specification or report was prepared by me or under my direct supervision and that I am a duly Licensed Professional Engineer under the laws of the State of Minnesota.

Plan Name: SEWER & C/P

Project: SEWER & C/P

Date: 2/15/2024, License Number: 3885

**ARDEN HILLS**

**Utstein**

4885 Lindeman Ave. SE  
 20, Pac. NW, Olympia, WA 98512  
 Phone: 360-485-3300  
 Email: [www.utstein.com](mailto:www.utstein.com)

**GRADING AND UTILITY PLAN**  
**KARTH LAKE STABILIZATION PROJECT**  
 ARDEN HILLS, MN

DESIGNED BY: ARNDT  
 CHECKED BY: CLAY  
 DATE: 02/15/2024 (SHEET NO. 02) (SHEET NO. 02) (SHEET NO. 02)

**Storm Sewer Profile**

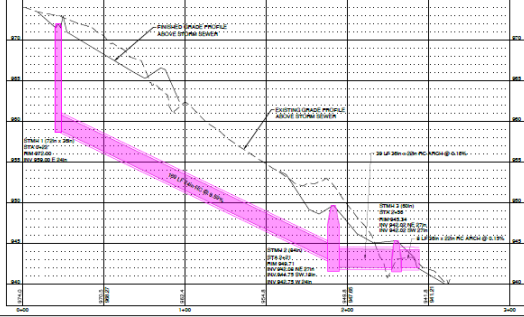

REVISION NO.	SHEET NO.
---	004

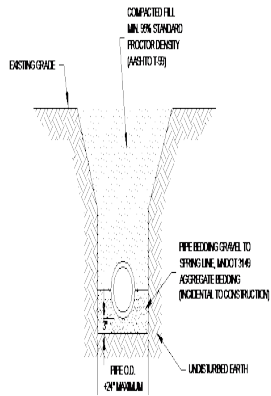

TRENCH BACKFILL DETAIL - RCPPVC

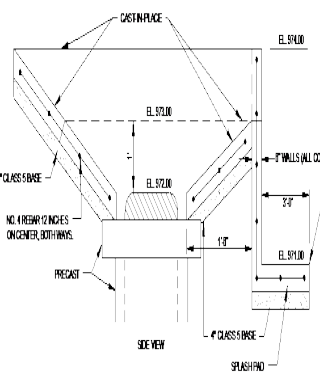
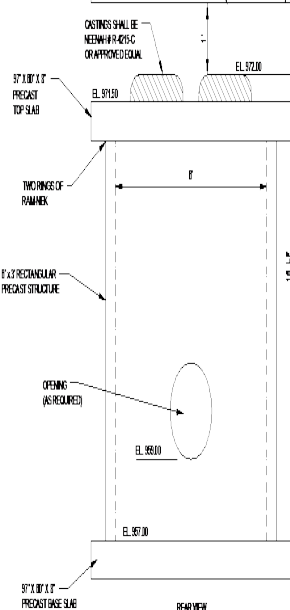
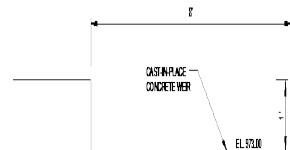
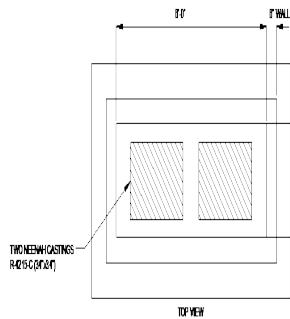
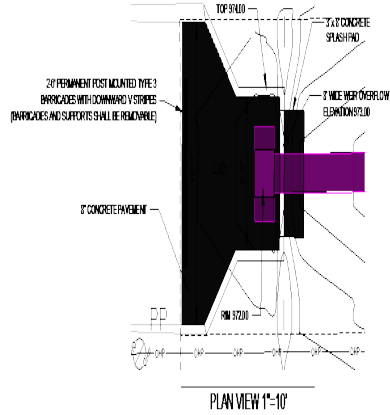

I hereby certify that the plans, specifications or report were prepared by me or under my direct supervision and that I am a duly Licensed Professional Engineer under the laws of the State of Missouri.

Professional Engineer License No. 0482  
 Date: 05/20/2024

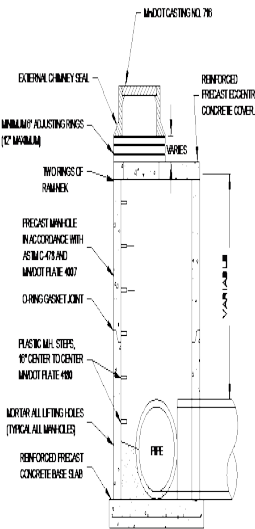

STORM MANHOLE

3' x 6' INLET STRUCTURE



DETAILS	
KARTH LINE STABILIZATION PROJECT ARDEN HILLS, MO	
DRAWN BY: J. DANSON	
CHECKED BY: K. CLAY	
DATE: FEB 09, 2024	